

Technische Information, Schleifeninstallation

Loop circumference	Number of windings
Under 3 m	Contact us
5 winding	3-6 m
4 winding	6-10 m
3 winding	10-25 m
2 winding	> 25 m

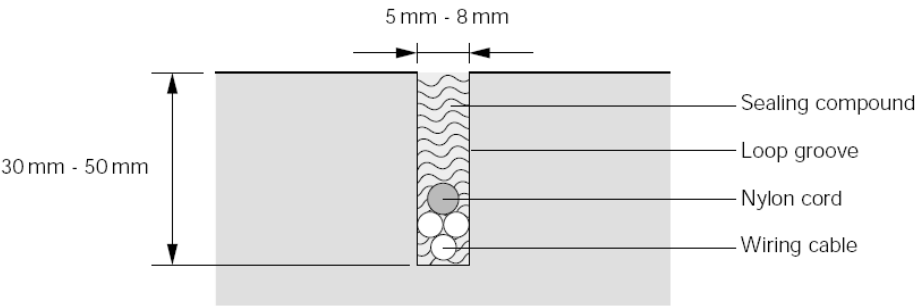

- Minimum distance of 1m between Loops when detected by different Loop detectors

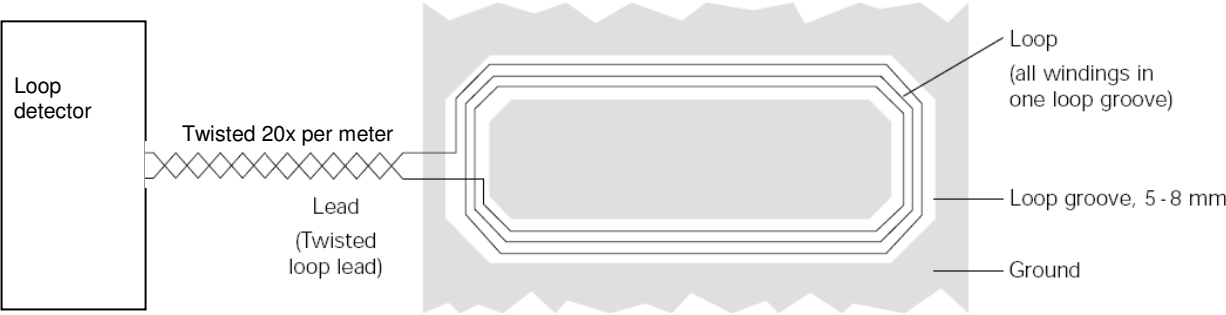
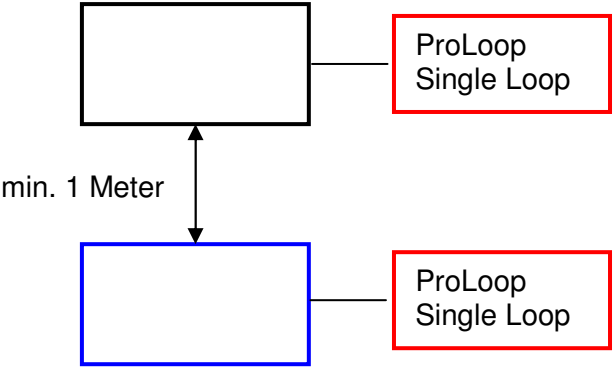

- No minimum distance between Loops when detected by same Loop detector

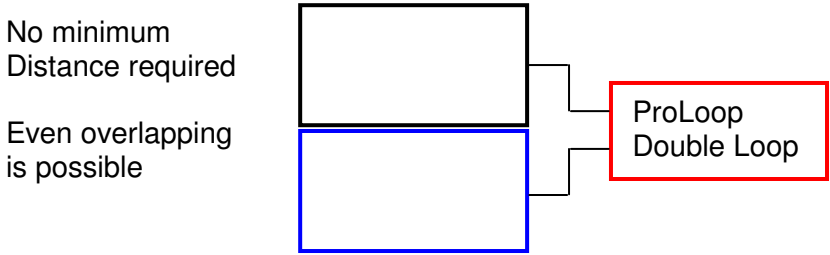

- Minimum distance of 1m between two pairs of Loops. Each pair can be used as described above. Important to set the loop detectors to different frequencies

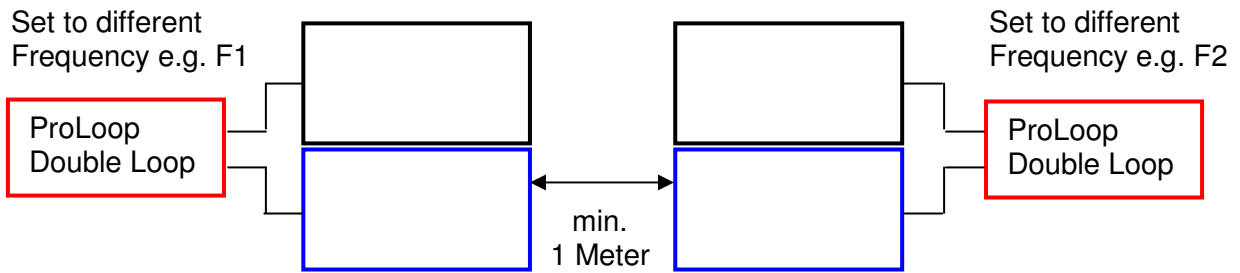

Grafik Auto/LKW

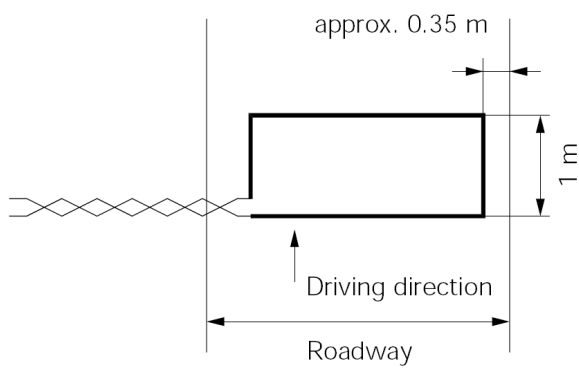

Grafik Fahrrad

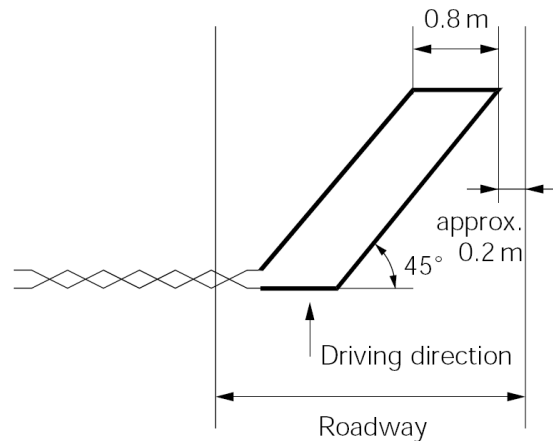

Applikation Schiebeter

